

SCREENINGS WASHER MONSTER®

Overview

JWC offers a selection of Screening Processing Equipment to serve a wide range of applications. All provide rugged construction and reliable operation to meet your specific needs.

The **Screenings Washer Monster-XE (SWM-XE)** pre-conditions screenings with a Muffin Monster two shafted grinder. The grinder breaks open rags, plastics and trash to promote washing and removal of soft organics. Liquefied organics return to the plant flow and allow the SWM-XE to achieve cleaner screenings. Pre-conditioned screenings also compact much better reducing the volume of screenings that must be hauled away. The SWM-XE features triple zone spray washing for the ultimate cleaning. The SWM-XE has numerous control parameters for programmable wash cycles. The compaction auger run cycle can be optimized with forward and reverse sequences for even cleaning screenings.

The SWM-XE unit can easily handle gravity main sewer first flush loading when the pre-conditioning grinder option is designed in.

Features & Benefits

Dual Shafted Grinder

- 30K or 40K Muffin Monster® grind solids for efficient washing and compacting.
- Handles first flush loading.
- Pre-Conditions solids for better organics removal.

Dual Helix Auger

- Rugged design compacts and squeezes water from solids.
- Exclusive brush attachment keeps screen clean and eliminates material catch points.

Wash Tank and Screening Trough

- 6mm perforated screen separates solids. 2 & 3mm openings also available.
- Two 4" (100mm) drain ports allow large launder flows up to 250 gpm (16 l/s).
- Multiple access ports for easy inspections.

Triple Zone Spray Wash

- Hopper system conveys screenings into the grinder.
- Upper tank wash cleans screenings and removes soft organics.
- Periodic lower tank wash flushes away sediment to maximize discharge flow.



Operation

1. Hopper transports screenings from screen to Screening Washer Monster.
2. Grinder breaks up material.
3. Screenings are washed, separated, dewatered and conveyed to compaction zone.
4. Soft organics (fecal) are liquefied, passed through the perforated screen and returned to the waste stream.
5. Screenings are dewatered, compacted, and conveyed to the discharge point where they emerge as a dry, solid plug.

Materials of Construction

Tank and Hopper: 304 Stainless steel (standard) - 316 Stainless steel (optional)

Piping: 304 Stainless steel (standard) - 316 Stainless steel (optional)

Auger: Alloy steel

Grinder: Ductile iron housing; Hardened alloy steel cutters

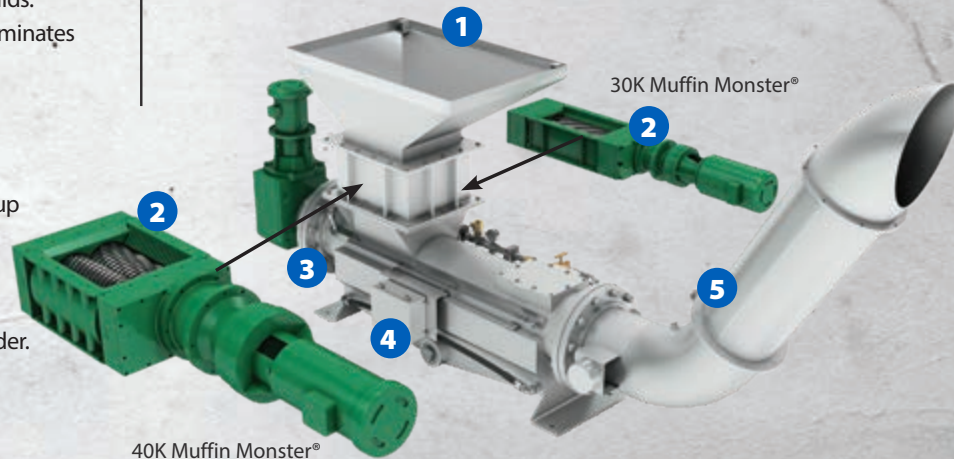

Screenings Washer Monster



Overview

The model XE Screenings Washer Monster is JWCE's top-of-the-line washer compactor. The patented XE is a fully automated grinding, washing and compacting system. It is finely tuned to optimize the cleanliness and dryness of screenings based on the feed rate. Our technology incorporates two decades of R&D and listening to our customers to produce the industry's finest washer compactor.

SWM-XE	Basic Model Dimensions - mm		
	A	B	C
SWM3018-XE	457	1765	470
SWM4018-XE	457	1765	470

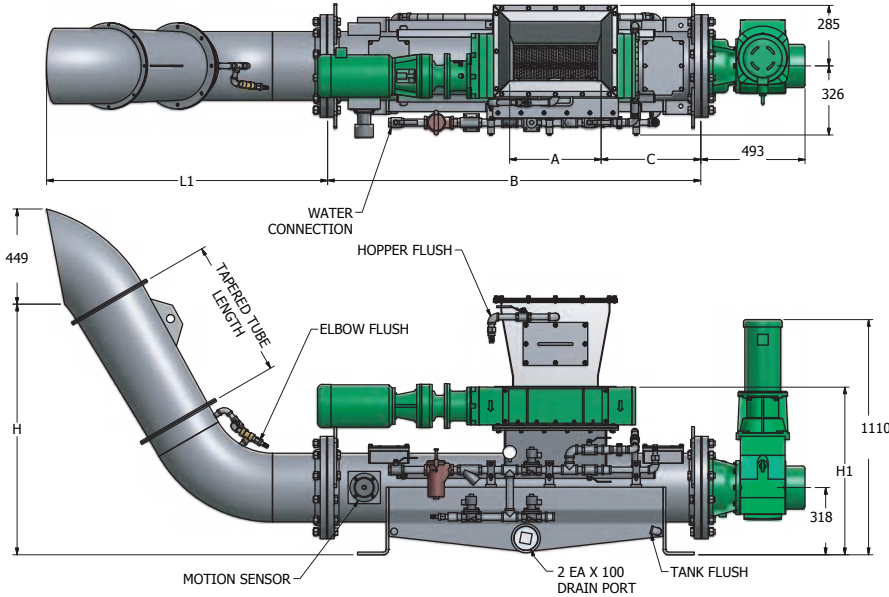

SWM-XE	Grinder Inlet Height - mm
	H1
SWM3018-XE	791
SWM4018-XE	879

Discharge Dimensions @60° - mm		
Taper Tube Length	H	L1
1000	1486	1501
1250	1703	1627
1500	1917	1751
1750	2137	1878
2000	2352	2001

Features		
SWM-XE	SWM3018-XE	SWM4018-XE
Grinder Motor - hp (kw)	3.7	7.5
Compaction Screw Motor - hp (kw)	2.2	(2.2)
Programmable Washing Cycle	Yes	Yes
Smart Controller™ Technology	Yes	Yes
Dedicated Wash Zone	Yes	Yes
Tank Flush	Yes	Yes
Compaction Elbow Flush	Yes	Yes
Motion Compaction-Sensor Screw	Yes	Yes
Upgradable To Add Grinder	Included	Included

Performance		
Max. Throughput - ft³/hr (m³/hr)	2.2	3.9
Optimized Output - ft³/hr (m³/hr)	1.3	2.3
Min. Organics Output - ft³/hr (m³/hr)	1.1	1.1
6mm Screen Water Capacity - gpm (l/s)	15.8	15.8
3mm Screen Water Capacity - gpm (l/s)	7.2	7.2
2mm Screen Water Capacity - gpm (l/s)	4.2	4.2



Before



After

Screenings Washer Monster

options



SWM-XE



Optional roller base makes moving the system quick and easy



Bagger



Custom hopper sizes and hopper covers



Custom hopper variation



Rags and trash are flushed into the cutters, where grinding and washing dislodge fecal matter.





JWC Environmental is a world leader in solids reduction and removal system for municipal wastewater collections, headworks and bio-solids operations. We offer our legendary Muffin Monster grinders and Monster Separation Screening systems, and IPEC industrial screens systems to solve unique wastewater processing situations.

JWC Environmental also services commercial and industrial applications with our Monster Industrial, and IPEC products. We are ready to take on challenging size reduction problems in industrial processes as well as help customers run efficient and compliant industrial wastewater treatment operations.

JWC Environmental is headquartered in Santa Ana, California, and has a global network of representatives, distributors and regional service centers to provide customer support. For more information, visit us at www.jwce.com.



**Unit 15, Daneside Business Park,
River Dane Road
Congleton, Cheshire
CW12 1UN, United Kingdom**
Phone: **+44 1260 277047**
Fax: **+44 1260 277557**



www.jwce.com