



# SCREENINGS WASHER MONSTER®

## Overview

JWC offers a selection of screening processing equipment to serve a wide range of applications. All provide rugged construction and reliable operation to meet your specific needs.

The **Screenings Washer Monster-XE (SWM-XE)** pre-conditions screenings with a Muffin Monster® two-shafted grinder. The grinder breaks open rags, plastics and trash to promote washing and removal of soft organics. Liquefied organics return to the plant flow and allow the SWM-XE to achieve cleaner screenings. Pre-conditioned screenings also compact much better; reducing the volume of screenings that must be hauled away. The SWM-XE features triple zone spray washing for the ultimate cleaning. The SWM-XE has numerous control parameters for programmable wash cycles. The compaction auger run cycle can be optimized with forward and reverse sequences for even cleaning screenings.

The SWM-XE unit can easily handle gravity main sewer first flush loading when the pre-conditioning grinder option is included.

## Features & Benefits

### Dual-shafted grinder

- 30K or 40K Muffin Monster grinds solids for efficient washing and compacting
- Handles first-flush loading
- Pre-conditions solids for better organics removal

### Dual-helix auger

- Rugged design compacts and squeezes water from solids
- Exclusive brush attachment keeps screen clean and eliminates material catch points

### Wash tank and screening trough

- 6 mm perforated screen separates solids; 2 and 3 mm openings also available
- Two 4" (100 mm) drain ports allow large launder flows up to 250 gpm (16 l/s)
- Multiple access ports for easy inspections

### Triple-zone spray wash

- Hopper wash system conveys screenings into the grinder
- Upper tank wash cleans screenings and removes soft organics
- Periodic lower tank wash flushes away sediment to maximize discharge flow



## Operation

1. Hopper transports screenings from screen to Screening Washer Monster
2. Grinder breaks up material
3. Screenings are washed, separated, dewatered and conveyed to compaction zone
4. Soft organics (fecal) are liquefied, passed through the perforated screen and returned to the waste stream
5. Screenings are dewatered, compacted, and conveyed to the discharge point where they emerge as a dry, solid plug

## Materials of construction

**Tank and hopper:** 304 stainless steel (standard) - 316 stainless steel (optional)

**Piping:** 304 stainless steel (standard) - 316 stainless steel (optional)

**Auger:** Alloy steel

**Grinder:** Ductile iron housing; hardened alloy steel cutters

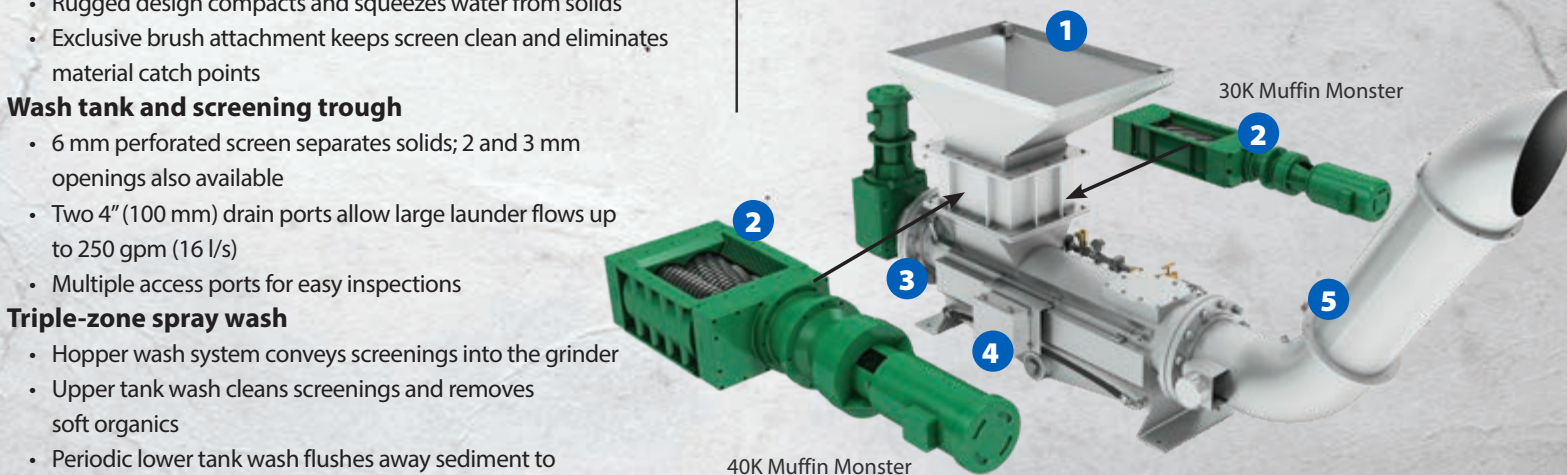

# Screenings Washer Monster



## Overview

The model XE Screenings Washer Monster is JWCE's top-of-the-line washer compactor. The patented XE is a fully automated grinding, washing and compacting system. It is finely tuned to optimize the cleanliness and dryness of screenings based on the feed rate. Our technology incorporates two decades of R&D and listening to our customers to produce the industry's finest washer compactor.

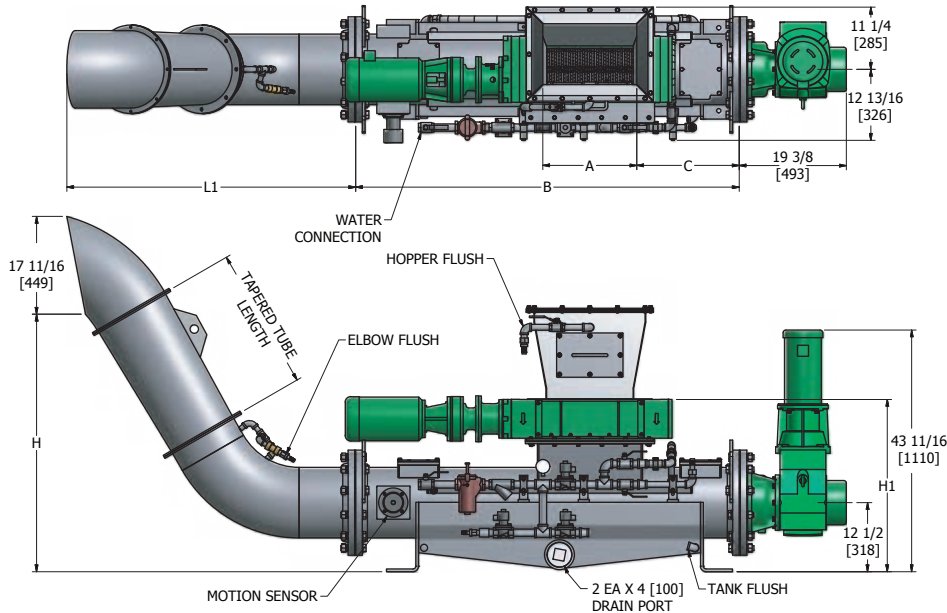

| SWM-XE     | Basic Model Dimensions<br>- inches (mm) |               |              |
|------------|---|---------------|--------------|
|            | A                                       | B             | C            |
| SWM3018-XE | 18 (457)                                | 69-1/2 (1765) | 18-1/2 (470) |
| SWM4018-XE | 18 (457)                                | 69-1/2 (1765) | 18-1/2 (470) |

| SWM-XE     | Grinder Inlet Height<br>- inches (mm) |
|------------|---------------------------------------|
|            | H1                                    |
| SWM3018-XE | 31-1/8 (791)                          |
| SWM4018-XE | 34-5/8 (879)                          |

| Taper Tube Length | Discharge Dimensions @60°<br>- inches (mm) |           |
|-------------------|--|-----------|
|                   | H  | L1        |
| 39-3/8 (1000)     | 58-1/2 (1486)                              | 59 (1501) |
| 49-1/4 (1250)     | 67 (1703)                                  | 64 (1627) |
| 59 (1500)         | 75-1/2 (1917)                              | 69 (1751) |
| 69 (1750)         | 84 (2137)                                  | 74 (1878) |
| 78-3/4 (2000)     | 92-1/2 (2352)                              | 79 (2001) |

| Features                         |            |            |
|----------------------------------|------------|------------|
| SWM-XE                           | SWM3018-XE | SWM4018-XE |
| Grinder Motor - hp (kw)          | 5 (3.7)    | 10 (7.5)   |
| Compaction Screw Motor - hp (kw) | 3 (2.2)    | 3 (2.2)    |
| Programmable Washing Cycle       | Yes        | Yes        |
| Smart Controller™ Technology     | Yes        | Yes        |
| Dedicated Wash Zone              | Yes        | Yes        |
| Tank Flush                       | Yes        | Yes        |
| Compaction Elbow Flush           | Yes        | Yes        |
| Motion Compaction-Sensor Screw   | Yes        | Yes        |
| Upgradable To Add Grinder        | Included   | Included   |

| Performance   |            |            |
|---|------------|------------|
| Max. Throughput - ft <sup>3</sup> /hr (m <sup>3</sup> /hr)      | 78 (2.2)   | 138 (3.9)  |
| Optimized Output - ft <sup>3</sup> /hr (m <sup>3</sup> /hr)     | 46 (1.3)   | 80 (2.3)   |
| Min. Organics Output - ft <sup>3</sup> /hr (m <sup>3</sup> /hr) | 38 (1.1)   | 38 (1.1)   |
| 6mm Screen Water Capacity - gpm (l/s)                           | 250 (15.8) | 250 (15.8) |
| 3mm Screen Water Capacity - gpm (l/s)                           | 114 (7.2)  | 114 (7.2)  |
| 2mm Screen Water Capacity - gpm (l/s)                           | 66 (4.2)   | 66 (4.2)   |



Before



After

# Screenings Washer Monster

## Options



SWM-XE



Optional roller base makes moving the system quick and easy



Bagger



Custom hopper sizes and hopper covers



Custom hopper variations



Rags and trash are flushed into the cutters, where grinding and washing dislodge fecal matter





*Since its founding in 1973, JWC Environmental has become a world leader in solids reduction and removal systems. For municipal wastewater collections, headworks and bio-solids operations we offer our legendary Muffin Monster grinders and Monster Separation Screening systems to solve unique processing situations.*

*JWC Environmental also supports commercial and industrial applications with our Monster Industrial, and IPEC products. We are ready to take on challenging size reduction problems in industrial processes as well as help customers run efficient and compliant industrial wastewater treatment operations.*

*JWC Environmental is headquartered in Santa Ana, California, and has a global network of representatives, distributors and regional service centers to provide customer support. For more information, visit us at [www.jwce.com](http://www.jwce.com).*



**Headquarters**  
2850 Red Hill Ave., Suite 125  
Santa Ana, CA 92705 USA  
toll free: **800.331.2277**  
phone: **949.833.3888**  
fax: **949.833.8858**  
email: [jwce@jwce.com](mailto:jwce@jwce.com)

[www.jwce.com](http://www.jwce.com)

