



# Muffin Monster®

Family of Grinders

## Mini Monster®

For lower flows, buildings, condos and resorts the Mini Monster is a powerful grinder in a compact package. It shreds rags and trash into tiny pieces in wastewater or sludge to protect pumps and eliminate costly breakdowns and back-ups.

## Muffin Monster

The workhorse of wastewater since 1973 the Muffin Monster easily reduces troublesome solids. The dual-shaft design uses low speed, high-torque power to shred tough solids in sewage and sludge. With over 30,000 installations the Muffin Monster is the proven solution for protecting pumps and systems.

## Macho Monster

For bigger solids reduction projects the Macho Monster has the power to keep up with the flow. The 40000 model uses 7-1/2" (190mm) cutters and the 70000 model uses massive 10" (254mm) cutters to slice through difficult solids. Ideal for sludge lines, prisons, waste-to-energy and food processing.



Dual shafted grinder



Easy pump station installation with custom frames.



In-Line Unit



Open Channel Unit

## Features & Benefits

### Dual Shafted Grinder

- Low-speed, high torque grinders handle rags, rocks, wood, clothing, plastics and other debris
- Capable of grinding a wider variety of solids than single shafted machines and macerators

### Compact and Efficient Design

- Adapts to pipelines or channels with little or no modification
- Custom stainless steel frames allow easy installation in channels, wet wells and pump stations
- In-line Mini and Muffin Monster incorporate easy to remove cutter cartridge

### Cartridge Seal Assembly

- High pressure capability up to 90 PSI (6 bar)
- Runs submerged or dry with no seal flush required

### Patented High-Flow Side Rails

- Increases flow capacity and decreases head loss
- Deflects solids into the cutting chamber

### Automated Monitoring and Controls

- Auto load sensing and reversals reduce interrupts and optimize the grinder's performance



**JWC**  
Environmental®

Trust Monster Quality™

www.jwce.com





# Applications

	Mini Monster	Muffin Monster	Macho Monster	Characteristics
Buildings, Resorts and Condos				Grinds up rags, cotton products and other trash frequently flushed down the toilet. Grinders are more powerful than grinder pumps and eliminate sewage pumping problems.
Pump Stations				Channel grinders can be installed on the wall of a wet well. In-line units are installed in dry pumping stations. Grinds solids to keep pumps running reliably and efficiently.
Septage / Grease				Grinds up rags, silverware, solids and trash as septage/grease are unloaded.
Sludge / Scum				Grinds up rag balls, rocks and plastics to protect sludge pumps.
Belt Press / Centrifuge				Grinds a variety of solids to protect dewatering systems from damage and makes them more efficient by homogenizing sludge prior to dewatering.
Jails / Prisons				Prevents clogs and spills. Installed in over 2,000 prisons, jails and institutional facilities.
Hospitals / Nursing Homes				Grinds up rags, pads, clothing, needles and dangerous waste to protect pumps & systems.
Food / Fish Processing				Grinds up material such as fish guts, slaughterhouse scraps, rendering material, food scraps and more. Frequently used in biogas applications to turn waste into energy.
Pulp / Paper				Installed in sludge lines, pulp systems and wastewater plants to protect pumps & pipelines.
Industrial				Used in refineries, hazardous waste processing, obsolete inventory destruction & recycling.

\* Consult factory for additional application assistance and approval.

# Photo Gallery



**Muffin Monster in-line grinders handling septage.**



**Muffin Monster in-line sludge grinder.**



**Macho Monster in-line sewage grinder in a jail.**



**Macho Monster in-line sludge grinders.**



**Muffin Monster grinder in a fish processing plant.**



**Muffin Monster channel grinder in a prison.**



**Muffin Monster pump station grinder and installation frame.**



**Muffin Monster pump station grinder and installation frame.**



# Mini Monster

Model 20000

## Standard Specifications

Model	Motor HP (kW)	Hex Size in. (mm)	Reducer	Cutter Size in. (mm)	Max Force at Cutter Tip lbs. (kN)
20000	3 (2.2)	2 (50)	29:1	4-3/4 (120)	6,150 (27.4)



*In-Line Unit*



*Open Channel Unit*

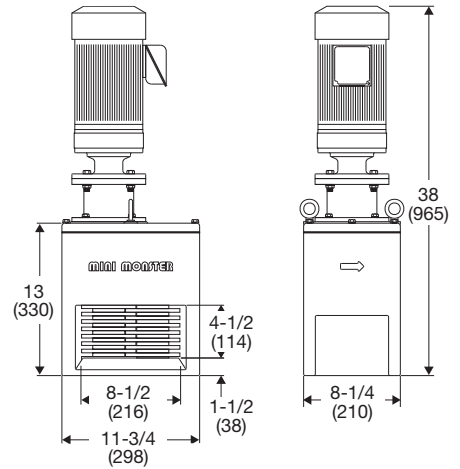

*Open Channel Configuration*

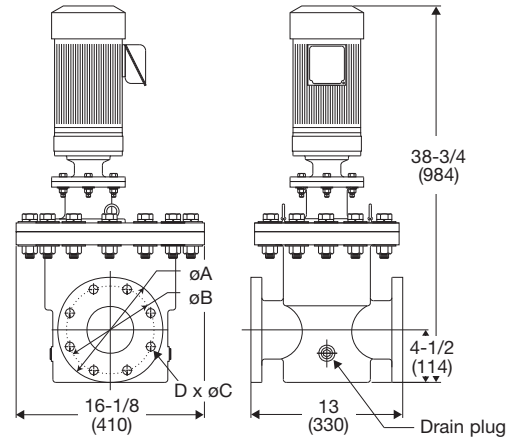

*In-Line Configuration*

## Performance Capability

Model	Configuration	Head Drop inches (mm)	Pressure Drop PSI (bar)	Max Pressure PSI (bar)	Flow Rate GPM (m <sup>3</sup> /h)	Approximate Net Weight lbs (kg)
20002	Open channel	3.8 (97)	n/a	90 (6)	80 (18)	225 (102)
20000	In-line	n/a	1 (0.07)	90 (6)	265 (60)	275 (125)

\* Notes: In-Line unit typically installed prior to suction side of pump. Flow based on optimum channel conditions. Consult factory for final analysis of application.

## Exclusive Features



*Removable Mini Monster cartridge*



*Removable Muffin Monster cartridge*



*Patented high-flow side rails (open channel configurations)*



*Exclusive hex driven, tungsten face seal cartridges*



**Removable  
Cutter  
Cartridge**

# Muffin Monster

Model 30000



**In-Line Unit**



**Open Channel Unit**

**Standard Specifications**

Models	Motor HP (kW)	Hex Size in. (mm)	Reducer	Cutter Size in. (mm)	Max Force at Cutter Tip lbs. (kN)
30004T / 30005	3 (2.2)	2 (50)	29:1	4-3/4 (120)	6,150 (27.4)
30004T / 30005	5 (3.7)	2 (50)	29:1	4-3/4 (120)	9,150 (40.7)

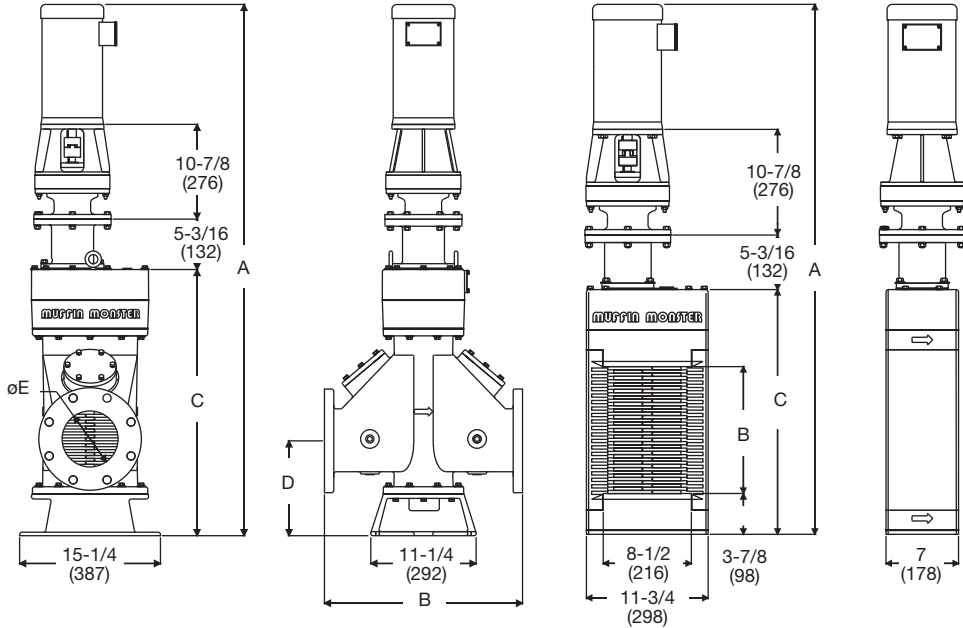

**In-Line Configuration**

**Open Channel Configuration**

**Performance Capability – Open Channel Configuration**

Model	Flow Rate GPM (m³/h)	Head Drop inches (mm)	Approximate Net Weight lbs (kg)	Dimensions - inches (mm)		
				A	B	C
30005-0008	335 (76)	9-1/2 (241)	370 (168)	48 (1219)	8 (203)	19-1/2 (482)
30005-0012	490 (111)	13-1/2 (343)	410 (186)	52-1/8 (1320)	12 (305)	23-5/8 (584)
30005-0018	740 (168)	17-1/2 (444)	465 (211)	58 (1473)	18 (457)	29-1/2 (736)
30005-0024	1000 (227)	19-1/2 (495)	520 (236)	63-3/4 (1600)	24 (609)	35-1/4 (889)
30005-0032	1470 (334)	21-1/2 (546)	580 (263)	71-1/2 (1803)	32 (813)	43 (1092)
30005-0040	2000 (454)	23-1/2 (597)	650 (295)	79-1/2 (2006)	40 (1016)	51 (1295)

\* Notes: Flow based on optimum channel conditions • Consult factory for final analysis of application • Dimensions based on 3 HP (2.2kW) electrical motor.

**Performance Capability – In-Line Configuration**

Model	Flow Rate GPM (m³/h)	Pipeline Size inches (mm)	Pressure Drop PSI (bars)	Max Pressure PSI (bars)	Approx. Net Weight lbs (kg)	Dimensions - inches (mm)				
						A	B	C	D	E
30004T-1204	400 (91)	4 (102)	0.42 (0.03)	90 (6)	550 (250)	56-1/4 (1423)	19-1/4 (483)	28-1/4 (711)	8-1/8 (206)	4 (102)
30004T-1206	600 (136)	6 (152)	0.86 (0.06)	90 (6)	560 (254)	56-1/4 (1423)	21-1/4 (534)	28-1/4 (711)	9-1/8 (232)	6 (152)
30004T-1208	800 (182)	8 (203)	1.60 (0.11)	90 (6)	570 (258)	56-1/4 (1423)	23-1/4 (584)	28-1/4 (711)	10 (254)	8 (203)
30004T-2410	1000 (227)	10 (254)	1.22 (0.08)	90 (6)	785 (356)	67-3/4 (1727)	27-1/4 (686)	39-3/4 (1010)	11-1/2 (283)	10 (254)
30004T-2412	1200 (273)	12 (305)	1.59 (0.11)	90 (6)	810 (367)	67-3/4 (1727)	31-1/4 (787)	39-3/4 (1010)	12 (305)	12 (305)

\* Notes: In-Line unit typically installed prior to suction side of pump.



# Macho Monster

Model 40000 and 70000



**In-Line Unit**

**Open Channel Unit**

**Open Channel Configuration**

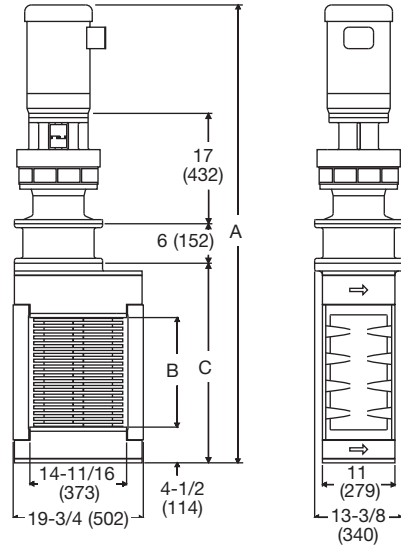

**In-Line Configuration**

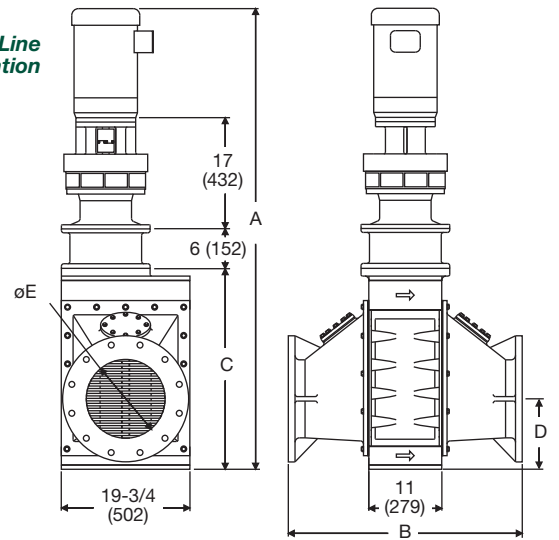

**Standard Specifications**

Model	Motor HP (kW)	Hex Size in. (mm)	Reducer	Cutter Size in. (mm)	Max Force at Cutter Tip lbs. (kN)
40002	10 (7.5)	2-1/2 (64)	43:1	7-1/2 (191)	16,237 (72)
70000	50 (37.5)	4 (102)	43:1	10 (254)	41,177 (183)

**Performance Capability - Open Channel Configuration**

Model	Flow Rate GPM (m³/h)	Head Drop inches (mm)	Approximate Net Weight lbs. (kg)	Dimensions inches (mm)		
				A	B	C
40002-0018	900 (204)	8 (203)	1175 (533)	69-1/4 (1754)	18 (457)	30-1/4 (768)
40002-0024	1500 (341)	16 (404)	1365 (619)	75 (1905)	24 (609)	37-1/4 (946)
40002-0032	2100 (477)	18 (457)	1560 (708)	76-1/4 (1937)	32 (812)	76-7/8 (1444)
70000-0040†	throughput 770 ft³/h (22 m³/h)		4200 (1900)	123 (3124)	41 (1041)	59 (1499)

† Typically used in material shredding applications.

**Performance Capability - In-Line Configuration**

Model	Flow Rate GPM (m³/h)	Pressure Drop PSI (bar)	Max Pressure PSI (bar)	Approx. Net Weight lbs (kg)	Dimension inches (mm)				
					A	B	C	D	E
40002-1812	2500 (500)	3.00 (.207)	90 (6)	1520 (690)	69-1/4 (1759)	35-1/4 (895)	30-1/4 (768)	10-3/4 (273)	12 (305)
40002-2412	3000 (681)	1.12 (.077)	90 (6)	1775 (805)	76-1/4 (1937)	35-1/4 (895)	37-1/4 (946)	10-3/4 (273)	12 (305)
40002-2416	3500 (795)	1.50 (.103)	90 (6)	1895 (860)	76-1/4 (1937)	43-1/4 (1099)	37-1/4 (946)	12-5/8 (321)	16 (406)
40002-2418	4000 (908)	2.20 (.152)	90 (6)	2095 (950)	76-1/4 (1937)	47-1/4 (1200)	37-1/4 (946)	13-5/8 (346)	18 (457)
40002-3220	5000 (1136)	3.00 (.207)	90 (6)	2610 (1184)	82-3/4 (2102)	51-1/4 (1301)	43-7/8 (1114)	15 (381)	20 (508)

\* Notes: In-Line unit typically installed prior to suction side of pump. Flow based on optimum channel conditions. Consult factory for final analysis of application.

# Muffin Monster Options



*Hardened steel cutters available in many sizes*

## Cutters

- 7, 11 and 13 tooth variations
- Special: 3-tooth fish grinding cutters
- Optional: extra-hard carburized cutters; stainless steel

## Custom Frames

- Stainless steel guide frames attach to pump station or channel walls to make installation easier
- Frame is customized to fit each site and includes: guide rails; grinder support base; subchannel; overflow bar racks and more

## High-tech Controllers

- Model PC2200 standard
- Standard enclosure: NEMA-4x fiberglass, 3 position switch and indicators
- Optional enclosures: NEMA-4x 304 stainless steel; NEMA-4x 316 stainless; NEMA-7 explosion proof



*High-tech Controllers*

## Scrapers

- Integrated steel scrapers increase throughput and help cutters clean-out faster. Improves performance of hopper fed applications.



*Custom stainless steel frames*



*Scrapers (optional)*



*Electric motor*



*Exclusive: JWC designed immersible motor (NEMA-6P)*



*Hydraulic drive*

## Motors

- TEFC - Totally enclosed fan cooled electric
- XPFC - Explosion proof fan cooled electric
- XPNV - Exclusive electric immersible
- Available in: 3, 5, 10 HP (2.2, 3.7, 7.5 kW)

## Hydraulic Power Packs

- Available in 5, 10, 15 HP (3.7, 7.5, 11 kW)

## Extended Motor Shaft

- Places motor above highest water level. Available in 6" (150mm) increments. Maximum: 12' (3600mm)



*Extended motor shaft*

# Service Options

## JWC offers several programs to choose from

- 1. MonsterCare:** Affordable service contract provides peace-of-mind and covers most grinder repairs.
- 2. Monster Exchange:** First we send a newly re-conditioned grinder; next, swap the new and old grinders and finally ship the old one back. Free labor with 1 year limited warranty.
- 3. Factory Repair:** We rebuild your grinder good as new. Free labor, 1 year limited warranty.
- 4. Parts:** Genuine Monster cutters, shafts and seals make a big difference.
- 5. Upgrade:** move up to the next generation of Monster grinding technology.



*Genuine Monster parts*

## Headquarters

290 Paularino Ave.  
Costa Mesa, CA 92626 USA  
Toll Free: (800) 331-2277  
Phone: (949) 833-3888  
Fax: (949) 833-8858  
jwce@jwce.com

## Western Product Support

2600 S. Garnsey St.  
Santa Ana, CA 92707, USA  
Toll Free: (800) 331-2277  
Phone: (949) 833-3888  
Fax: (714) 751-1913  
jwce@jwce.com

## Eastern Product Support

4485 Commerce Dr, Ste 109  
Buford, GA 30518, USA  
Toll Free: (800) 331-8783  
Phone: (770) 271-2106  
Fax: (770) 925-9406  
jwce@jwce.com



[www.jwce.com](http://www.jwce.com)